

# SCM12 / SCM12-C

## Description

SCM12 is an high performance board, targeted for CAN OPEN and 10Mbit Ethernet. Due to highly integrated design (surface mount technology), based on CRYSTAL LAN™ 8900 controller, SCM12 offers broad range of performance features and options, including unique PacketPage architecture, which automatically adapts to changing network traffic patterns and available system resources. The SCM12-C board has installed CoDeSys™ softlogic system.

### Technical data:

CPU.....79RV3041 *Idt Risc processor*  
 Flash memory.....1 Mbyte  
 SDRAM memory.....8 Mbyte  
 CPU supervisor  
 (Reset, Watchdog).....Yes  
 Serial Eeprom memory.....25F064 8Kb  
 Ethernet 10 Base-T.....CRYSTAL CS8900A  
 CAN Port.....CAN 2.0

## Ethernet Port

Pin	Signal
1	TD out +
2	TD out -
3	RX in +
6	RX in -

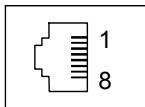

RJ45  
PINOUT

**There are two diagnostic indicators :**

**LINK ( red ):** LED is on if no network signals have been detected or in case of general failure of the SCM12.



Use cable and connector RJ45 shielded

## CAN Port

Pin	Signal
2	CAN_L
3	CAN_GND
7	CAN_H

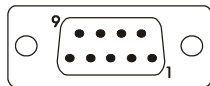

1 MANSCM12-001 V.1.05 01.12

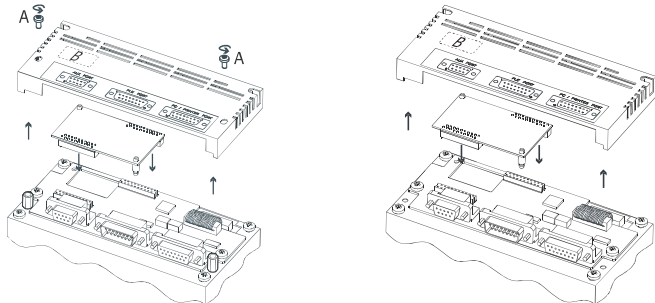
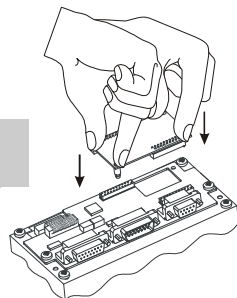

Figure 2 – Mounting SCM12 board.



Insert the module pressing simultaneously on the four corners.



Do not plug/remove the module and the ETAD adapter when power is applied to the operator panel.



Confirm that the location is free from explosively hazardous gases or dust before connecting or disconnecting equipment, replacing or wiring modules. Confirm that the power supply has been turned OFF before disconnecting, replacing or wiring modules.



For use in ATEX environment (atmosphere explosive): check that the module is mounted on a panel satisfying minimum IP54 degree of protection for category 3G and IP6x for category 3D and the requirements relating to the 3G or 3D categories in Zones 2/22 (Category 3: normal level of protection - G: Gas - D: Dust).

3 MANSCM12-001 V.1.05 01.12

## Diagnostics

The system provides some diagnostic information of the communication modules on the operator panels.

To access the diagnostic information:

- Recall the System Menu from the Operation Mode
- Scroll down to display the bottom row of the page

The diagnostic information will be shown as in the example below:

### SCM12 0 H280 X240 OK

SCM12	type of communication module
0 H280 X240	internal version codes (N.B.: Subject to change)
OK	confirmation of the correct operation of the module

SCM12 is connected via the additional adapter board ETAD 03, equipped with a standard RJ45 and DB9 male connectors:

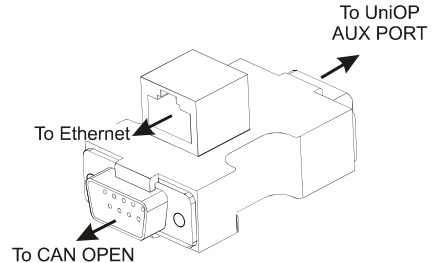

## Mounting the Module

The mounting procedure for the module is the following:

- 1) Turn off the operator panel.
- 2) Remove the rear cover (if present, release not completely with a screwdriver the two screws "A" fixing the rear cover)..
- 3) Plug the module in the red connectors and make sure they are properly latched, plug possible adaptor (ETAD).
- 4) Replace the rear cover.
- 5) Stick in the area "B" the label indicating the type of module which has been plugged.

2 MANSCM12-001 V.1.05 01.12



These modules are also for Exor International S.p.A. control panels marked ATEX, II 3 G D  
 Ex nA II T4  
 Ex tD A22 IP65 T80°C  
 T Amb: 0°C - 50°C  
 T Amb: -20°C - 70°C heavy range

The product has been designed for use in an industrial environment in compliance with the 2004/108/CE directive  
 This device has been designed for use in potentially explosive atmospheres in accordance with 94/9/EC Directive

Equipment group II, category 3 intended for use in potentially explosive atmospheres zones 2/22, G:gas and D:dust.

The product has been designed in compliance with:

- |              |                  |
|--------------|------------------|
| EN 61000-6-4 | EN 55011 Class A |
| EN 61000-6-2 | EN 61000-4-2     |
|              | EN 61000-4-3     |
|              | EN 61000-4-4     |
|              | EN 61000-4-5     |
|              | EN 61000-4-6     |

EN 60079-0

EN 60079-15

EN 61241-0

EN 61241-1

Type examination certificate number: CEC 09/2008-AET 491 X

4 MANSCM12-001 V.1.05 01.12

# SCM12 / SCM12-C

## Descrizione

SCM12 è un modulo ad alte prestazioni, mirato per una rete CAN OPEN ed Ethernet a 10Mbit. Merito di un progetto di alta integrazione, basato sul controllore CRYSTAL LAN™ 8900. SCM12 offre moduli con varie gamme di prestazioni caratteristiche e opzioni, incluse unicamente nell'architettura PacketPage, la quale automaticamente si adatta ai cambiamenti del traffico della rete disponendo un sistema di ricerca. Il modulo SCM12-C installa il sistema CoDeSys™ softlogic.

### Caratteristiche tecniche:

CPU.....79RV3041 *Idt Risc processor*  
 Flash memory.....1 Mbyte  
 SDRAM memory.....8 Mbyte  
 CPU supervisor  
 (Reset, Watchdog).....Yes  
 Serial Eeprom memory.....25F064 8Kb  
 Ethernet 10 Base-T.....CRYSTAL CS8900A  
 CAN Port.....CAN 2.0

### Ethernet Port

Pin	Signal
1	TD out +
2	TD out -
3	RX in +
6	RX in -

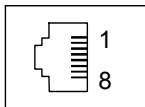

RJ45  
PINOUT

Inoltre sono previsti due LEDS :  
**LINK** (LED rosso): Acceso se non è stato trovato il segnale di rete o in caso di avaria generale del SCM12.



Utilizzare cavo e connettore RJ45 schermati

### CAN Port

Pin	Signal
2	CAN_L
3	CAN_GND
7	CAN_H

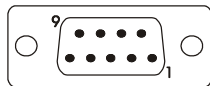

1 MANSCM12-001 V.1.05 01.12

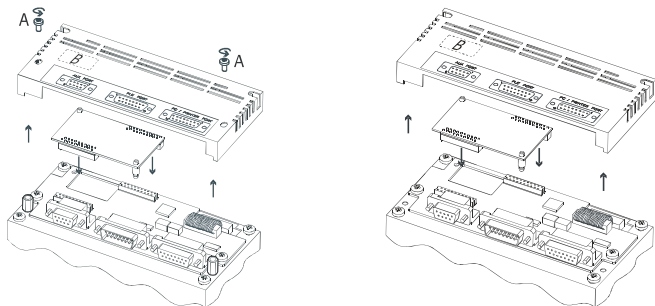
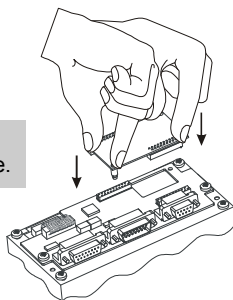

Figure 2 – Montaggio modulo SCM12



Inserire il modulo premendo sui quattro angoli contemporaneamente.



Non inserire/togliere il modulo (ed eventuali adattatori ETAD) a macchina accesa.



Prima di collegare o scollegare l'apparecchiatura, sostituire o cablare moduli, controllare che l'area di lavoro sia priva di gas o polveri potenzialmente esplosive. Controllare che l'alimentatore sia spento prima di scollegare, sostituire o cablare i moduli.



Per l'utilizzo in ambiente ATEX (atmosfera esplosiva): controllare che il modulo sia montato su una apparecchiatura che soddisfi almeno il grado di protezione IP54 per la categoria 3G e IP6x per la categoria 3D, ed i requisiti riguardanti le categorie 3G o 3D nelle Zone 2/22 (categoria 3: livello normale di protezione - G: gas - D: polvere).

3 MANSCM12-001 V.1.05 01.12

## Diagnostica

Il corretto inserimento e funzionamento del modulo può essere verificato nella maniera seguente:

- con pannello in Operation Mode attivare il menu System
  - effettuare lo scroll verso il basso fino all'ultima riga
- il pannello mostrerà una riga diagnostica che avrà questa forma:

### SCM12 0 H280 X240 OK

SCM12                      nome del modulo  
 0 H280 X240              codici interni di versione (N.B.: Soggetto a variazione)  
 OK                            conferma inserimento corretto

SCM12 è collegato attraverso un modulo adattatore addizionale ETAD 03, equipaggiato con un connettore RJ45 e DB9 maschio:

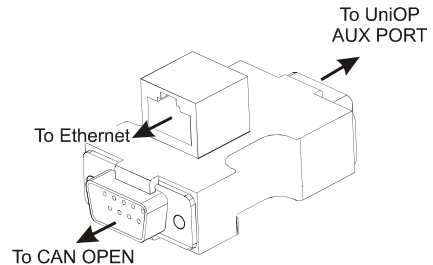

## Montaggio

La procedura di montaggio dei moduli è la seguente:

- 1) Spegner il pannello.
- 2) Rimuovere il coperchio (se presenti, svitare non completamente le due viti "A" che fissano il coperchio dei connettori).
- 3) Inserire il modulo negli appositi connettori rossi ed assicurarsi che siano correttamente agganciati, connettere eventuali adattatori (ETAD).
- 4) Rimontare il coperchio.
- 5) Applicare nello spazio "B" tratteggiato sul coperchio l'etichetta che descrive le caratteristiche della porta AUX.

2 MANSCM12-001 V.1.05 01.12



Questi moduli sono adatti per apparecchiature prodotte da Exor International S.p.A. marcate ATEX, II 3 G D  
 Ex nA II T4  
 Ex tD A22 IP65 T80°C  
 T Amb: 0°C - 50°C  
 T Amb: -20°C - 70°C gamma pesante

Il prodotto è stato progettato per l'impiego in ambiente industriale in conformità alla direttiva 2004/108/CE

Questo prodotto è stato progettato per l'impiego in atmosfera potenzialmente esplosiva in conformità alla direttiva 94/9/CE.

Apparecchiature di gruppo II, categoria 3 utilizzabili in atmosfere potenzialmente esplosive Zone 2/22, G: gas e D: polveri.

Il prodotto è stato progettato in conformità alle norme:

- |              |                  |
|--------------|------------------|
| EN 61000-6-4 | EN 55011 Class A |
| EN 61000-6-2 | EN 61000-4-2     |
|              | EN 61000-4-3     |
|              | EN 61000-4-4     |
|              | EN 61000-4-5     |
|              | EN 61000-4-6     |

EN 60079-0

EN 60079-15

EN 61241-0

EN 61241-1

Certificato di esame di tipo numero: CEC 09/2008-AET 491 X

4 MANSCM12-001 V.1.05 01.12

CoDeSys is a registered trademark  
 Copyright © 2006-2012 Exor International S.p.A.  
 Exor International S.p.A. - San Giovanni Lupatoto  
 VR, Italy  
 www.uniop.com